

# **Analysis of the Instrument Picking Process in a Case Cart System at the University of Michigan Hospital**

## **Team 6 Final Recommendation Report**

**University of Michigan Health System:**

**Program and Operations Analysis**

---

**Submitted To:**

Karen Bett, Central Sterilization Supply Manager: University of Michigan Hospital System  
Linda Lawrence, Instrument Room Interim Manager: University of Michigan Hospital System  
Mark Van P. Oyen, Ph.D: Dept. of Industrial & Operations Engineering, University of Michigan  
Matt Claysen, Project Coordinator: Program and Operations Analysis  
Mary Duck, Project Coordinator: Program and Operations Analysis

**Prepared By:**

Team 6, Case Cart Team  
Chris Charnow, IOE 481 Student  
Poorvi Modi, IOE 481 Student  
Amanda Sage, IOE 481 Student  
Matt Staton, IOE 481 Student

**Date Submitted:**

December 17, 2010

# Table of Contents

<b>Table of Contents</b> .....	ii
Executive Summary .....	1
Introduction.....	4
Background.....	4
Congestion Due to Current State Process .....	5
Improved Work Flow in Future State Process .....	7
Downstairs in the CSPD .....	8
Upstairs in the OR Cores .....	8
Case Scheduling .....	8
Project Scope .....	9
Goals and Objectives .....	10
Data Collection Methods .....	10
Literature Search .....	10
Informal Interviews.....	10
Instrument Picking and Staging Time Studies .....	11
Historical Data.....	11
Key Findings and Conclusions .....	11
Informal PT Interview Responses.....	11
Instrument Picking and Staging Time Studies Results .....	12
Case Delivery Model .....	13
First 27 Cases of the Day by 6:00 AM.....	14
Second and Third Cases of the Day .....	15
81 Cases of the Day by 6:00 AM .....	16
Emergent Case Model .....	18
True Emergency .....	18
Urgent Cases.....	18
Recommendations.....	19
First 27 Cases of the Day by 6:00 A.M.....	19
Second and Third Cases of the Day .....	20
81 Cases of the Day by 6:30 A.M. ....	20

Emergency Cases .....	20
Urgent Cases .....	20
Summary of Quantitative Recommendations .....	21
Color Coded Stickers .....	21
Manual double checking .....	21
Barcode system .....	22
Summary of Qualitative Recommendations .....	22
Expected Impact.....	23
Acknowledgments.....	24
Appendix A: Blueprints of UMHS Operation Room Cores .....	25
Overview of UH OR Core A Layout .....	26
Overview of UH OR Core B Layout.....	27
Overview of UH OR Core C Layout.....	28
Overview of CSPD Layout .....	29
Appendix B: Value Stream Maps of Current State.....	30
Appendix C: Hospital Equipment.....	31

## List of Figures

Figure 1. Dimensions for frontal view of case cart prototype.....	5
Figure 2. Current Staffing schedule for instrument processors (IPs) and PTs.....	6
Figure 3. Chart of current instrument transportation, sterilization and picking process.....	6
Figure 4. Sterilized, finished Genesis Cases and wrapped instruments.....	7
Figure 5. The 2010 80 <sup>th</sup> percentile surgical case demand of a typical 24 hour day for Monday, Tuesday, Wednesday and Friday .....	9
Figure 6. Pareto Chart depicting the average processing times for the 8 services.....	13
Figure 7. Future state model to pick and stage the first 27 case carts of the day .....	15
Figure 8: Future state model to pick and stage the second and third cases of the day.....	16
Figure 9: Future state picking and staging to complete case carts for all cases of the day by 6AM .....	17
Figure 10: Future state model to pick and stage true emergency cases .....	18
Figure 11: Future state model to pick urgent cases.....	19
Figure 12: Barcode on a Genesis Case for a neurology surgical case.....	22

## List of Tables

Table 1: Descriptive statistics for individual task processing times.....	13
Table 2: Descriptive statistics for picking and staging processing times.....	21
Table 3: Pros and Cons for Each Recommendation for Quality Checking .....	23

# EXECUTIVE SUMMARY

The University of Michigan Hospital (UMHS) is currently renovating its basement to install a Central Sterilization Supply Department (CSPD) which includes additional decontamination, sterilization and storage areas to support the overflow of surgical instruments. The separation of surgical instrument location and Operation Rooms (ORs) will require a case cart system to safely and efficiently maneuver surgical instruments from the CSPD to the ORs. UMHS plans to order 100 case carts to assist in the instrument transportation which provides more cargo and safety features relative to the current standard of bipods. The Central Sterile Supply (CSS) Manager and Instrument Room Interim Manager would like to know the specifics of the current instrument picking and staging process to better understand how the process will be affected after the case cart system is implemented. In the case cart system, the instrument processors in the CSPD will be responsible for picking the hard surgical instruments while the perioperative technicians (PTs) in the OR Cores will pick the associated soft supplies. The purpose of this project was to model the schedule of parallel picking of instruments in the CSPD and the OR Cores with minimum staffing so that the hospital can meet average surgical case demand.

## Background

The hospital supports 3 OR Cores containing 9 ORs each which totals to 27 ORs. Average surgical case demand is 72.7 cases per day with roughly 27 of those served by 7:30 A.M. The surgical case or service types are categorized as the following: neurology, general surgery, orthopedics, gynecology, ears nose and throat (ENT), trauma/burn (TBE) and minimal invasive surgery (MIS), plastic surgery and oral surgery. Currently, all hard surgical instruments, soft supplies and bipods (means of transporting surgical supplies) are stored in the OR cores. To reduce the congestion, all the hard instruments will be stored in the CSPD. Case carts will also replace the bipods and be stored in the CSPD.

## Methodology

The team collected data using the following methods: literature search, interviews, time studies, observations and historical data analysis.

- *Literature Search* – A previous OMS 490 class recommended PTs to pick instruments 2.5 hours in advance of the surgery start time. The team’s goal is to further reduce this processing time. In addition, previous case cart projects in general approached the problem from a very high level view whereas this project will probe deeply into the instrument picking and staging process.
- *Interviews* – The team interviewed the PTs to determine their highest priority problems with the current picking and staging process, better understand the task breakdown within the process and identify areas of waste.
- *Time Studies* – The team performed time studies of the picking and staging process to collect the required times to:
  1. Print Pick Sheet and place on available bipod.
  2. Pick soft supplies.
  3. Pick hard instruments.
  4. Stage bipod outside of respective OR.

- *Observations* – The team closely observed the walking path of the PTs during the time study and their arrangement of soft and hard supplies on the bipods. Qualitative suggestions for waste reduction and improvement were documented.
- *Historical Data Analysis* – The Project Coordinator provided historical data for fiscal years 2010 and 2011 (since it is ongoing, 2011 only has data from July-Sept) regarding surgical case type, case length and case demand. Data excluded holidays, seasonal days, weekends and Thursdays to retain accuracy. Thursday is excluded due to morning staff meetings that delay the instrument picking process.

## **Key Findings and Conclusions**

After performing time studies of the current picking and staging process, the processing times necessary for picking and staging in the future state were determined. These processing times apply to picking and staging according to a 24-hour continuous surgical case demand or a demand of all 81 case carts by 6:00 A.M.

The processing times from 75<sup>th</sup> percentile for the tasks performed downstairs in the CSPD are the following:

- Print Pick Sheet and find case cart: 30 seconds
- Pick hard instrument sets: 8 minutes
- Load Elevator with 4 case carts: 1 minute, 30 seconds

The processing times from the 75<sup>th</sup> percentile for the tasks performed upstairs in the OR Cores are the following:

- Print Pick Sheet and find laundry basket: 30 seconds
- Pick soft supplies: 11 minutes for the first 4 case carts and 10 minutes, 30 seconds for all subsequent case carts
- Unload 4 case carts from elevator: 1 min, 30 seconds
- Stage 4 case carts with laundry basket: 1 minute

For a true emergency, if a pre-prepared trauma cart is stored upstairs for each service, the case cart should be ready in 2 minutes by 1 PT.

For an urgent case, the case cart can be picked and staged in 6 minutes if 2-3 instrument processors pick the instruments in the CSPD and 3-4 PTs pick the soft supplies together in the OR Cores.

## Recommendations

### Quantitative recommendations:

- Staff two groups of 5 instrument processors and 4 PTs (18 total) to commence instrument picking for the first cases of the day at 5AM to stage case carts outside ORs by 6AM.
- Alternatively, staff one group of 5 instrument processors and one group of 4 PTs (9 total) to commence instrument picking for the first cases of the day at 4:30 AM to stage case carts outside ORs by 6AM if hospital needs a reduced staff.
- Staff one group of 4 instrument processors and 4 PTs to commence instrument picking for subsequent cases of the day at 8:30 AM when demand reduces to 8 cases/hour.
- To pick case carts for all 81 cases by 6:00AM, instrument picking in the CSPD should begin at 2:52 AM and soft supply picking in the OR Cores should begin at 2:30 AM. Loading the staged case carts for the first 27 cases of the day into the elevator should begin at 5:30 AM. This entire picking and staging process will require 4 instrument processors in the CSPD and 4 PTs in the OR Cores. Only one instrument processor in the CSPD will be responsible for staging the case carts next to the elevator and loading the elevator respectively.
- Prepare trauma carts for all service types and store in appropriate OR Core to ensure case cart delivery in less than 5 minutes.
- Engage multiple PTs and instrument processors in the picking of urgent cases to ensure case cart is delivered in less than 10 minutes.

### Qualitative recommendations:

- Utilize the existent color coding system effectively to serve as a quality check. Place color coded stickers on both Pick Sheets and hard instrument sets (Genesis cases and wrapped instruments). This method can sustain for short-term usage until a more sustainable option is fully implemented.
- Designate the instrument processor that finishes picking the last case cart of each batch to check all instrument sets of the batch against their corresponding Pick Sheets before loading the elevator.
- Continue implementing the barcode system that uses a scanner to ensure the instrument sets match the surgical case needs on the Pick Sheet. This method will ensure the highest rate of access and is sustainable for long-term usage.

## **INTRODUCTION**

The University of Michigan Hospital System (UMHS) is implementing a case cart system to assist the transportation of surgical instruments from sterilization to the Operation Rooms (ORs). The Central Sterilization Supply Manager and Instrument Room Interim Manager would like to know how the instrument picking and staging process will be affected by the new case cart system. The picking process includes gathering all the instruments and supplies for each surgical case. Staging involves transporting the correct case cart to the OR room. The hospital includes 3 OR cores with 9 to 10 ORs in each core. Since the OR cores house storage for all the instruments, supplies and bipods, the core hallways have become heavily congested posing a safety hazard for hospital staff. The Central Sterilization Supply (CSS) Manager and Instrument Room Interim manager report that the congestion creates insufficient space for the perioperative technicians (PTs) and for patients to safely navigate through the crowded OR Cores. UMHS is currently renovating its basement to install a Central Sterile Processing Department (CSPD) downstairs for new sterilizers and one room for hard instrument and case cart storage. Disposable or “soft” supplies (e.g. blankets, sutures) along with delicate or specialty instruments will remain upstairs in the OR Cores. The purpose of this project is to develop an instrument picking procedure that can be divided between the OR cores and the CSPD while meeting surgical case demand throughout the day.

## **BACKGROUND**

Each OR Core serves different types of surgical cases. Core A serves Ear, Nose and Throat (ENT), neurosurgery, oral, and orthopedic spinal surgeries. Core B serves general surgery, orthopedics, plastic surgery, and some oral surgeries. Core C serves gynecology, urology, general surgery, trauma/burn (TBE) and minimal invasive surgery (MIS). Currently, the hospital uses bipods to store and stage the surgical instruments for each surgical case. The hospital will replace the bipods by ordering 100 case carts which are represented by the prototype in Figure 1. Instead of being stored in the OR cores like the bipods, the case carts will be stored in the CSPD which will reduce congestion in the OR Cores. In the future state, instrument processors will pick hard surgical instruments only in the CSPD in addition to sterilizing and assembling instruments. Upstairs in the OR Cores, the PTs will simultaneously pick disposable or “soft” supplies and place them in a large laundry basket or bin which will be stored on shelves until further use. The results of this project will identify how far in advance picking should start for case carts to be ready for each surgical case, the minimum staffing required to meet surgical case demands, a procedure to accommodate emergent surgical cases and a quality check to ensure correct case carts reach the ORs. To achieve these goals, the Case Cart team has interviewed PTs, performed time studies of the picking and staging process and analyzed historical surgical case demand data.



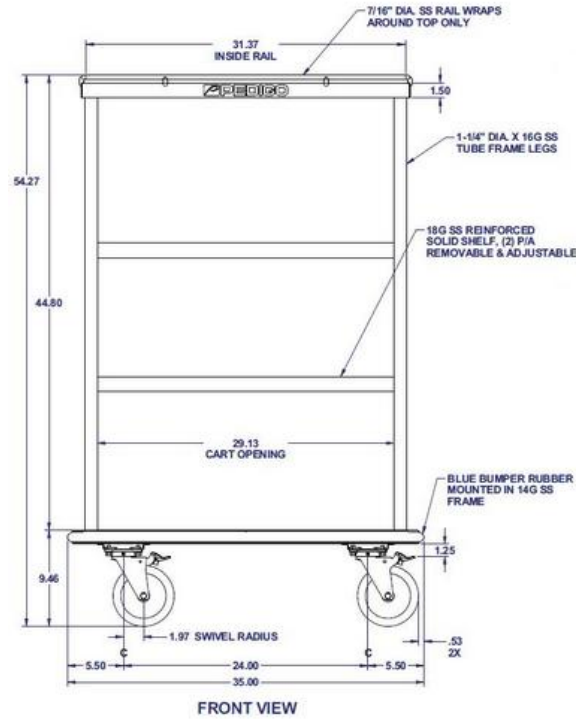

Figure 1. Dimensions for frontal view of case cart prototype. *Provided by Project Coordinator, November 2010.*

## Congestion Due to Current State Process

The current state process of cleaning, sterilizing, and picking instrument bipods is congesting the OR Core hallways. All hard instrument sets, soft supplies and bipods are stored and picked in the OR Cores. In the current state, only the PTs pick and stage the bipods of instruments in the OR Cores while the instrument processors assemble and sterilize the instrument sets in the CSPD and in decontamination rooms located on the same floor as the OR Cores. Figure 2 shows the current staffing of instrument processors and PTs for each shift. One can observe that the majority of instrument processors work during later hours of the day when the bulk of instrument sterilization takes place. The majority of PTs work during the afternoon shifts when the bulk of soft supplies are picked for the next day's set of surgical cases.

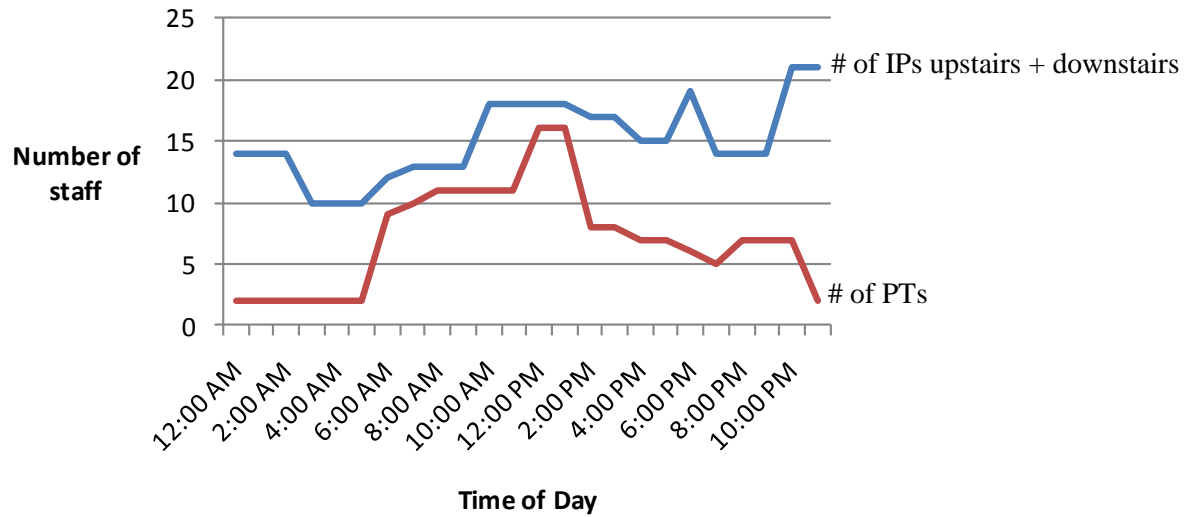

Figure 2. Current Staffing schedule for instrument processors (IPs) and PTs. *Data provided by Heather Mlynczyk.*

The current state process begins when the surgical technicians transfer soiled instruments from the ORs to the UH OR decontamination room and ends when an instrument processor stacks the sterilized instrument sets on the shelves within the OR Cores for the PTs to pick for each surgical case. Figure 3 summarizes the entire work flow of instruments and highlights the picking process that is central to our project’s focus. The current instrument picking process begins immediately after decontamination and sterilization of the instruments.

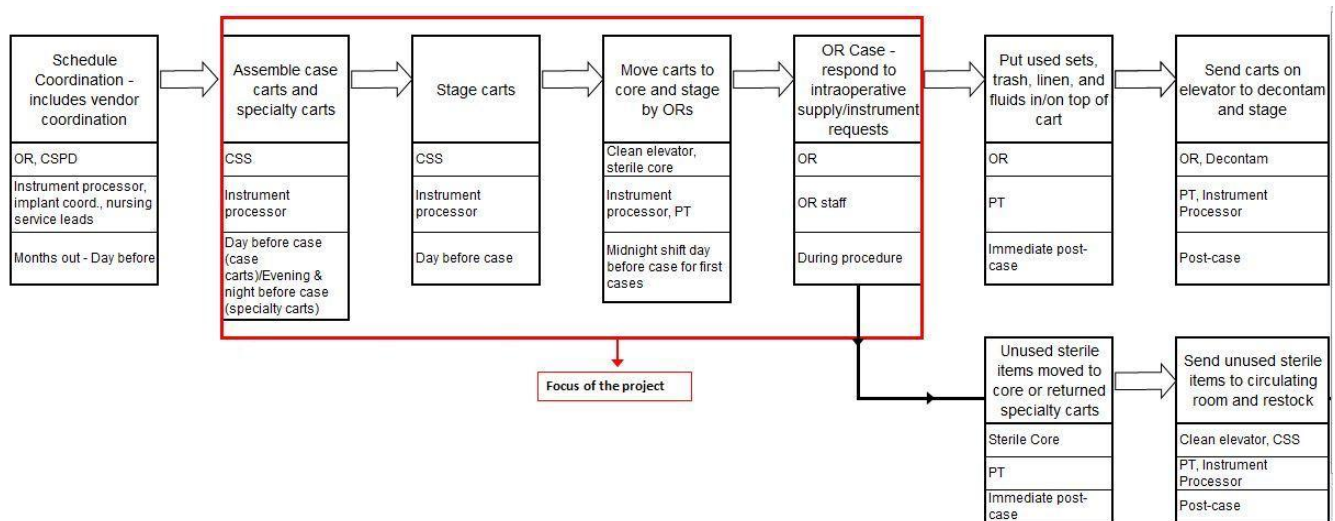

Figure 3. Flow Chart of current instrument transportation, sterilization and picking process. *Provided by Project Coordinator, November 2010.*

As seen in Figure 3, the picking process begins after schedule coordination between OR and CSPD.

1. PTs will print the surgical case schedule of the day and the corresponding Pick Sheets associated with each surgical case. The Pick Sheet is a detailed list of instrument sets and soft supplies required for the specific surgical case. The Pick Sheet also contains an “Additional Comments” section where doctors will make special item requests that must also be picked.
2. The PTs collect as many bipods as needed and place one Pick Sheet on each bipod. The PTs line up the bipods in each of their respective cores depending on the surgical case. For example, if a bipod has a gynecology Pick Sheet, it will be lined up in Core C.
3. The PT locates a bipod with a Pick Sheet and views the disposable or “soft” items on the list. The PT will pick the soft supplies first in the current core. If supplies are located in other cores, the PT will usually pick those next.
4. After picking all the soft supplies, the PT will view the hard instrument sets needed on the sheet and pick those in the current core. If instrument sets are located in other cores, the PT will pick those next. Instrument sets are either wrapped in blue sterilization paper or in Genesis case containers as depicted in Figure 4.



Figure 4. Sterilized, finished Genesis Cases and wrapped instruments. *Photograph taken by IOE 481 Team 6, October 2010.*

When the hospital needs all case carts prepared for 81 surgical cases by 6:30 A.M., the hard instruments are usually picked during the midnight shift (10:00 P.M.-6:30 A.M.) while soft supplies are picked during the afternoon shift before (1:30 P.M.-5:30 P.M.). The hard instruments are picked at midnight because sterilization and decontamination can take 3 hours to complete.

### **Improved Work Flow in Future State Process**

The future state picking and staging processes for the implemented case cart system will be divided between the OR Cores and the CSPD and act in parallel. The future state will require an

effective radio communication system between the OR Cores and CSPD. Instead of all equipment being picked by PTs at once in the OR Cores, hard instruments will be picked downstairs by instrument processors while soft supplies will be picked in the OR Cores by PTs. There are only two elevators—one for clean and one for soiled instruments. This process focuses on the clean elevator with capacity of 4 case carts which travels from Core A to the CSPD and vice versa.

### **Downstairs in the CSPD**

1. The instrument processors will print Pick Sheets for the first 7:30 AM surgical cases (1 per OR) and place one Pick Sheet on each case cart.
2. During each cycle, 4 instrument processors will pick for 4 surgical cases since the elevator can only accommodate 4 case carts at a time. To optimize time, the 4 cases picked during each cycle will be selected based off similar processing times so case carts are finished roughly in sync. The instrument processors will locate a case cart with a Pick Sheet and pick only the hard surgical instrument sets which are stored in the shelving area of the CSPD.
3. After picking, the instrument processors will load his or her respective case cart in the elevator. When all 4 are in the elevator, the elevator will be sent up to Core A to combine with soft supplies.

### **Upstairs in the OR Cores**

1. Simultaneously while hard instruments are being picked downstairs, the PTs will similarly print Pick Sheets for the first 7:30 AM surgical cases and place one Pick Sheet on a laundry basket or bin.
2. During each cycle, 4 PTs will pick soft supplies for the same 4 surgical cases as the instrument processors downstairs. Soft supplies will be stored in laundry baskets and placed on shelves in the core of their corresponding surgical case.
3. Since there are typically more soft supplies required to be picked than hard instruments, the instrument processors will finish picking first. 1 extra PT will unload the elevator as it arrives in Core A, send the elevator back downstairs and distribute the case carts to their appropriate Cores. The case carts will be stored underneath shelves and the other 4 PTs will place the laundry basket on the shelf above each corresponding case cart. When a case cart is needed, the PT will place the laundry basket of soft supplies on top of the case cart and stage it outside the appropriate OR.

This general process will continue for the second and third cases of the day though at a much a slower pace with reduced staffing.

### **Case Scheduling**

In the current state, Pick Sheets and surgical case schedules are printed twice a day. First set of Pick Sheets for the first 27 cases of the day are typically printed between 4:00 -4:30 A.M. and

instrument picking commences 4:30 A.M.-5:00 A.M so the bipods for the first cases of the day are ready an hour before the surgical cases at 7:30 A.M. For second and third cases of the day, the final set of Pick Sheets is printed 1:00-1:30 P.M. and soft supply picking commences 1:30-2:00 P.M.

The picking process differs based on the whether the PTs are picking for the first case of the day versus subsequent cases. As shown in Figure 5, demand is highest for the first surgical cases starting at 7:30 AM where all 27 ORs need a case cart. From 8:30AM-5:00PM, demand dramatically decreases to roughly 8 surgical cases/hour. From 5:00PM-midnight, the demand is even less (~2 cases/hour) including mostly add-ons and emergent cases. Based on the data in Figure 5, the hospital averages about 72.7 surgical cases total per 24-hour weekday.

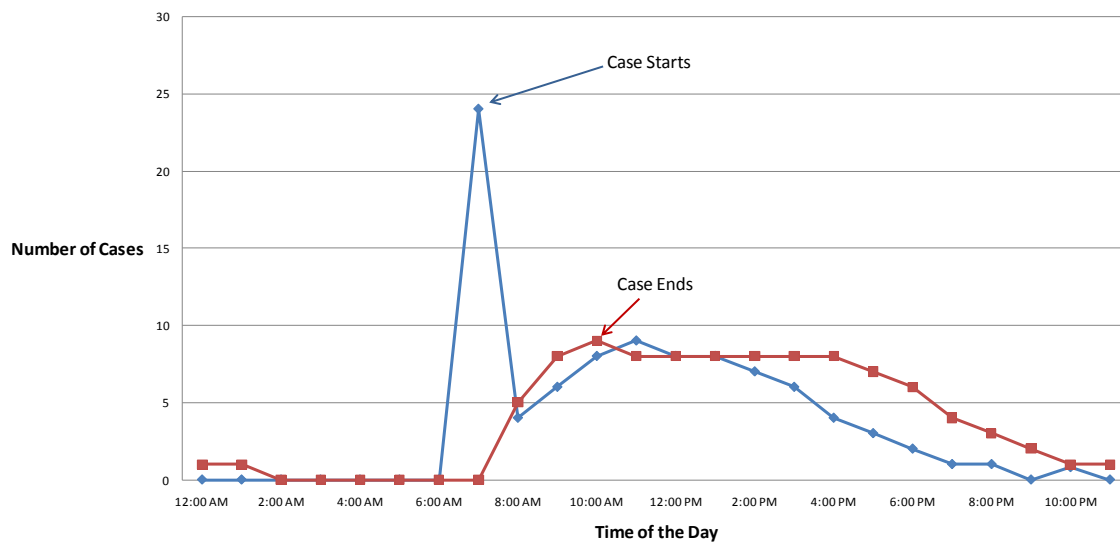

Figure 5. The 2010 80<sup>th</sup> percentile surgical case demand of a typical 24 hour day for Monday, Tuesday, Wednesday and Friday (excluding weekends, seasonal and holidays).  
*Provided by Project Coordinator, November 2010.*

Compare the demand in Figure 5 and the current staffing in Figure 2. One can observe that since the demand peaks at 7:30 A.M., the hospital must staff the majority of instrument processors several hours before 7:30 A.M. to sterilize and prepare the instrument sets in time for the first 27 cases of the day.

## PROJECT SCOPE

This project focused on identifying all stages of the current instrument picking and staging process. The project identified exactly what the instrument picking and staging tasks entail, the order of the tasks, and the time required to complete each individual task. To determine the staging logistics of the case carts, the project considered the differences in processing time among services. The results of the project will integrate a system for improving quality and

accuracy in the case cart process. The project will further address a standardized procedure for staging and transporting case carts during emergency and last-minute scenarios.

While the case cart process involves many stages including picking, transportation, cleaning and sterilization, this project specifically will focus on the picking piece, excluding details of the other stages involved. This project will not cover tasks performed while the case carts are inside an OR. This project will not modify the layout or equipment planned for the renovated CSPD area downstairs. This project will not identify which case carts remain within the ORs and which case carts will be stored in the basement. This project will not look at whether correct instruments are being placed inside the Genesis cases or what happens when the sterilization tape breaks. The project will also assume adequate staffing and will not recommend any additional staffing.

## **GOALS AND OBJECTIVES**

The primary goal of this project is to design an efficient and accurate process for the transportation of case carts from the new CSPD downstairs to the OR Cores upstairs. The team's objectives included the following:

- Determine times and location for the staging of future case carts to reduce congestion.
- Observe differences in instrument picking based on scheduled or emergent cases to develop a standardized procedure to transport case carts during emergency situations.
- Streamline a faster, more effective, yet feasible communication system from OR cores to CSPD.
- Develop qualitative best practices to reduce number of wrong instruments delivered.

## **DATA COLLECTION METHODS**

To better understand the current state picking and staging process the team used the following methods for data collection: literature search, informal interviews, time studies, observations and historical data analysis.

### **Literature Search**

The team referred to previous IOE 481 reports regarding instrument processing, the case cart system and PT workload to gain a better understanding of how all three topics are interconnected. This information also served a valuable purpose by helping the team and client define a scope and problem that had not been addressed before.

### **Informal Interviews**

The team interviewed 2 PTs in each of the 3 cores and the Patient Tech Associate (supervisor to PTs) to determine the following information:

- Identify the highest priority problems associated with the picking process in the current state
- Understand the task breakdown within instrument picking and bipod staging
- Identify waste in the picking and staging process and opportunities for improvement

## **Instrument Picking and Staging Time Studies**

The team performed time studies during the hours 6:00 A.M.-7:30 A.M. and 1:00 P.M.-3:00 P.M. from November 15-18, 2010. Time studies were performed to observe the current state instrument picking and staging process for all 8 services (refer to *Background* or Figure 5 for service types). The team recorded individual times required to complete the following:

- Print the Pick Sheet plus find a bipod and place the Pick Sheet on the bipod.
- Pick soft supplies.
- Pick hard instruments.
- Stage bipod outside the OR room.

In addition to processing times, the team recorded the number of hard instrument sets picked per service, the number of total supplies picked per service, and identified any waste in the process.

## **Historical Data**

The Project Coordinator provided historical data for fiscal years 2010 and 2011 (since it is ongoing, 2011 only has data from July-Sept) regarding surgical case type, case length and case demand. Data excluded holidays, seasonal days, weekends and Thursdays to retain accuracy. Thursday is excluded due to morning staff meetings that delay the instrument picking process.

## **KEY FINDINGS AND CONCLUSIONS**

The following section provides the team's qualitative and quantitative findings and conclusions. The qualitative findings include informal interviews with the PTs and the Patient Care Tech Associate. The quantitative findings include the results from the instrument picking/staging time studies and the surgical case delivery models for first cases of the day, subsequent cases of the day, true emergencies and urgent cases.

### **Informal PT Interview Responses**

The team interviewed 2 PTs per Core about the instrument picking process. Their main concerns in order of highest priority are:

- Space is a concern to safely maneuver bipods which can stack up to 3 or 4 layers of instrument sets at a time.

- PTs lift heavy Genesis cases from high shelves and bend too much to reach Genesis cases on the bottom shelves. OSHA Policy states that instruments must be shelved at least 6 inches from the ground and 12 inches from the ceiling to maintain sterilization. Given more space, the instrument shelving could be designed ergonomically to eliminate these problems.

These findings suggest that space and safety appear to be the biggest main concern over the timing of the current process. When all the hard instruments transfer to the CSPD, the OR Cores will be much less congested allowing more free space for PTs to pick the soft supplies. Since the hospital is ordering 100 case carts, the safety issues associated with the bipods will be resolved.

Next, the team interviewed the Patient Care Tech Associate (PT supervisor) about the current state emergency case procedure. Her responses can be summarized as the following:

- During an emergency case, the picking process takes about one third the usual time to assemble a bipod with the correct hard instruments and soft supplies. This can be accomplished when multiple PTs work together to pick all the supplies.
- In order to notify the PTs what to pick, a Pick Sheet for the emergency case is generated by the front desk clerk who calls the PT over the radio. Calling the PT takes 30 seconds.
- The hospital currently has a trauma bipod that contains all supplies and instruments needed for any trauma coming into the OR without enough notice for a case to be picked. The trauma bipod is pulled into the room, supplies are used and once the case finishes, the trauma bipod is replaced. It is preferred, however, that the trauma bipod is picked according to the specific Pick Sheet.

For the current state, the existent emergency procedure is proactive and quick because all PTs are instructed to help with the emergency picking process and trauma bipods are available. For the future state, the emergency procedure may be affected due to the storage of hard instruments in the CSPD.

## **Instrument Picking and Staging Time Studies Results**

The team performed time studies of current state instrument picking and staging for 24 total surgical cases. Figure 6 captures the differences in picking times for each of the different surgical cases. Neurology, general surgery and orthopedics tended to have longer processing times, but they also required a larger number of hard and soft supplies (30, 60, 40, average total supplies respectively). Hard and soft supplies required for a general surgery case were also scattered across all cores. The extra walking distance contributed to a longer average processing time. The time study results, as indicated in Table 1, show that picking soft supplies generally requires more time (mean of 6 minutes, 42 seconds) than picking hard instruments (mean of 3 minutes, 33 seconds). However, picking time for hard instruments and soft supplies had similar variances. The picking and staging process requires on average a total of 10 minutes and 55 seconds to complete.



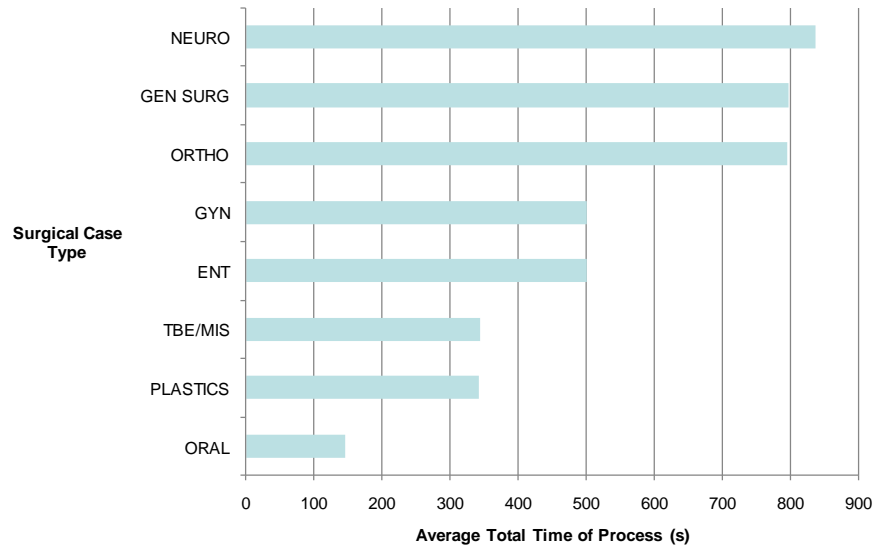

Figure 6. Pareto Chart depicting the average processing times for the 8 services.

Table1. Descriptive statistics for individual task processing times.

Task	Mean Time	Standard Deviation	75th Percentile	Mean Number of Items
Print Pick Sheet	5.25 s	4 s	8.75 s	-
Find Bipod	18 s	45 s	7.5 s	-
Pick Soft Supplies	6 min 42 s	3 min 58 s	8 min 11 s	44 supplies
Pick Hard Instruments	3 min 33 s	3 min 56 s	5 min	6.6 sets
Staging	32.83 s	40 s	43 s	-
<b>Total</b>	10 min 55s	7 min 21 s	13 min 35 s	50.6 supplies

Using the current state time study data, the team was able to model the times necessary to complete the same tasks in the future state. The team developed three models: one for the first 27 cases of the day, one for second and third cases of the day and an emergent case model. Together the three models can serve as one model for a typical 24 hour day. All models incorporated the team's assumptions, staffing requirements and change in surgical case demand throughout the day.

## CASE DELIVERY MODEL

To depict the task scheduling of the future picking and staging process, several models were developed based off these general assumptions:

- The models only apply to Monday, Tuesday, Wednesday and Friday workloads. Weekends, seasonal days, and holidays were excluded since they experience a much

lower demand. Thursday was also excluded because weekly staff meetings take place in the morning which delays the surgical case start time.

- The processing times are based off the 75<sup>th</sup> percentile of the collected time study data so that 75% of the processing times fall within this range.
- The elevator will require 1 minute to travel one way.
- Loading or unloading the elevator will require 30 seconds.
- The elevator will always be loaded to a maximum capacity of 4 case carts at a time before being sent upstairs to the OR Cores.
- Cases will always be picked in batches of 4 (1 per instrument processor or PT) so that elevator is always loaded at maximum capacity.
- Ideally, each batch of 4 case carts to be picked should be chosen from similar services to close the gap among processing times. Yet the 75<sup>th</sup> percentile time frame should be generous enough to accommodate batches of different surgical case types.
- All hard instruments are sterilized and ready before picking begins.

### **First 27 Cases of the Day by 6:00 AM**

The processing times used for the model were based off a weighted average equation. Minitab software was used to calculate the 75<sup>th</sup> percentile of the collected time study data for each of the instrument picking and staging tasks. The sample size of the collected time study data was 24 surgical cases. Historical data from July to September 2011 indicated the frequency of each surgical case type. 4,846 surgical cases were performed within this timeframe.

$$\text{Future State Processing Time} = \sum_{n=0}^{11} \text{Probability of Case Type}_n * 75\text{th Percentile}_n$$

for n = surgical case type (e.g. neurology, general surgery, orthopedics, ...)

Based on the model shown in Figure 7, the processing times from the 75<sup>th</sup> percentile for the tasks performed downstairs in the CSPD are the following:

- Print Pick Sheet and find case cart: 30 seconds
- Pick hard instrument sets: 8 minutes
- Load Elevator with 4 case carts: 1 minute, 30 seconds

Based on the model shown in Figure 7, the processing times from the 75<sup>th</sup> percentile for the tasks performed upstairs in the OR Cores are the following:

- Print Pick Sheet and find laundry basket: 30 seconds
- Pick soft supplies: 11 minutes for the first 4 case carts and 10 minutes, 30 seconds for all subsequent case carts
- Unload 4 case carts from elevator: 1 min, 30 seconds
- Stage 4 case carts with laundry basket: 1 minute

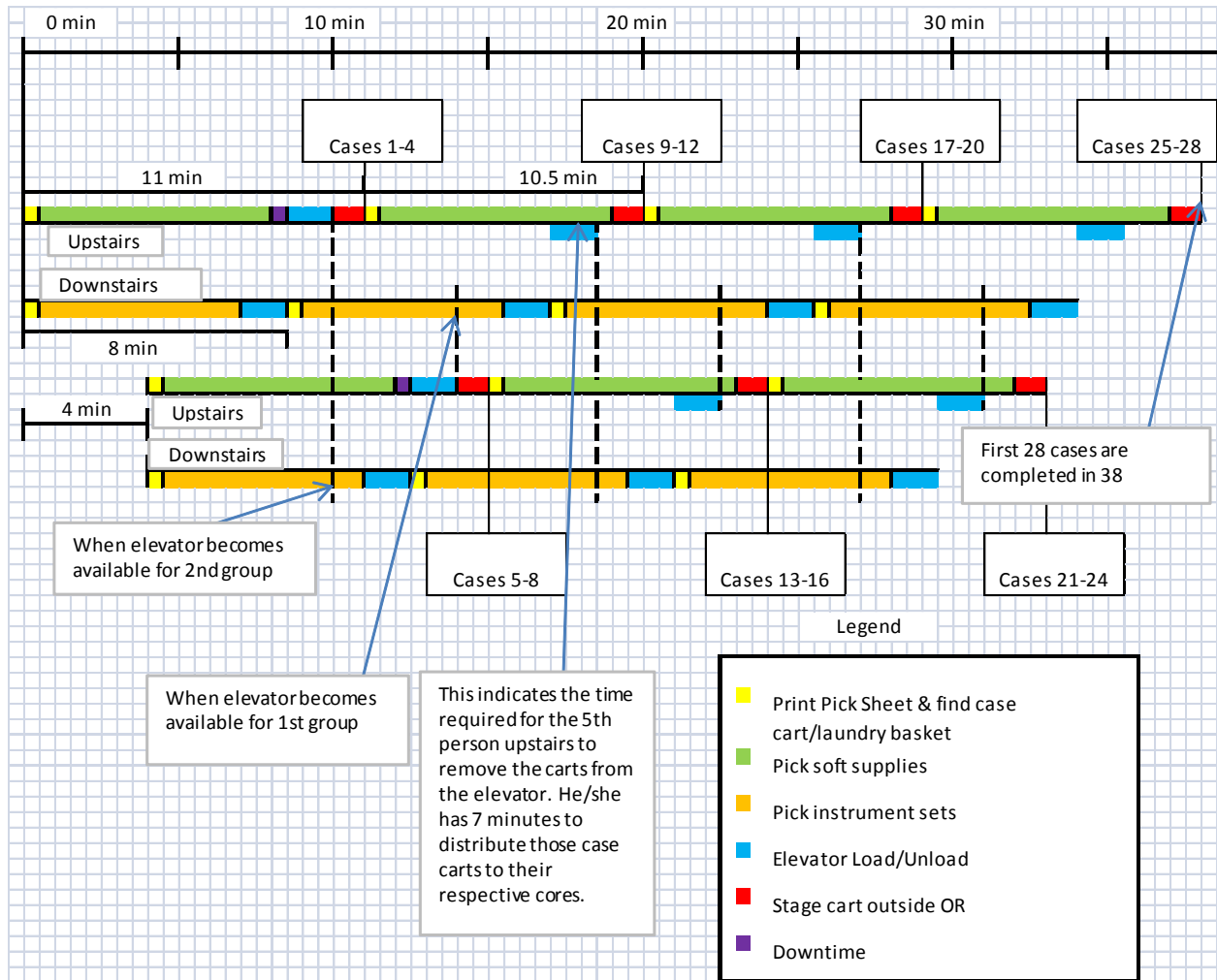

Figure 7. Future state model to pick and stage the first 27 case carts of the day.

The staffing will require two groups of 5 PTs in the OR Cores and two groups of 4 instrument processors in the CSPD.

### Second and Third Cases of the Day

Based on surgical case demand presented in Figure 5, the hospital serves roughly 8 surgical cases/hour after the first surgical cases of the day. The second and third cases of the day occur between 8:30 A.M. and 5:30 P.M. With this steep reduction in demand, workload for picking and staging will dramatically decrease. As shown in Figure 8, the entire picking and staging process will approximately take 21.5 minutes for 8 case carts. The remaining 38.5 minutes in this model

will be allocated to downtime where PTs can assume their other tasks and duties (44 minutes of downtime for instrument processors). When the new hour commences, the same cycle will repeat until 5:30 P.M. at which surgical case demand is reduced even further.

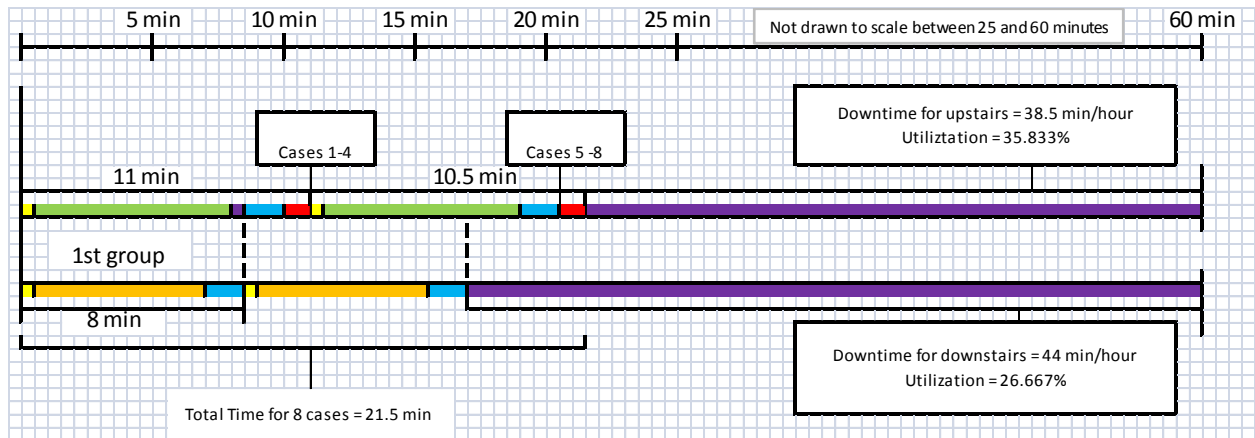

Figure 8. Future state model to pick and stage the second and third cases of the day.

The staffing will require 4 PTs in the OR Cores and 4 instrument processors in the CSPD.

## 81 Cases of the Day by 6:00 AM

Part 1 in Figure 9 shows the instrument picking and soft supply picking processes to complete 81 case carts. Four PTs upstairs will pick soft supplies for case carts (green) and place the laundry baskets on a shelf near where the case cart will be staged outside the OR (red). In the current state, the soft supply picking is usually completed during the afternoon shift when PT staffing is highest. However, Figure 9 depicts a possible solution if soft supply picking were to occur during the midnight shift, closer in time to the instrument picking. With 4 PTs working only on picking soft supplies and placing the baskets by the ORs, this process will require a total of 3 hours or 9 minutes per 4 case carts. If the soft supply picking begins at 2:30 A.M., all laundry baskets full of soft supplies for 81 cases can be completed by 5:30 A.M.

Four instrument processors will be picking hard instruments in the CSPD (orange) and staging carts near the elevator (red). Four instrument processors picking 81 case carts and staging the case carts by the elevator will require a total of 157.5 minutes. This means that 4 instrument processors should begin picking hard instrument sets at approximately 2:52 AM to finish at the same time as the soft supply picking at 5:30 A.M.

The purpose of Figure 9 is for both instrument picking and soft supply picking to end at the same time. Then the case carts needed for the first 27 cases of the day will all be loaded into the elevator at once and staged outside the ORs.

Part 1: Picking and Staging

Upstairs : Pick soft supplies in laundry basket and place completed basket on shelf.

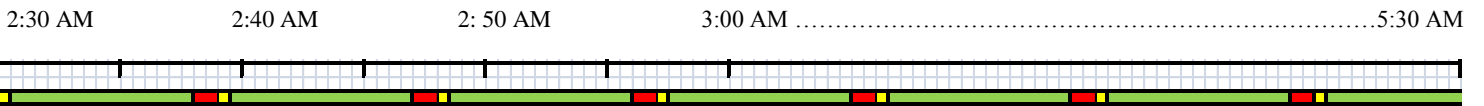

Downstairs: Pick hard instruments on case cart. Stage case cart in queue next to elevator.

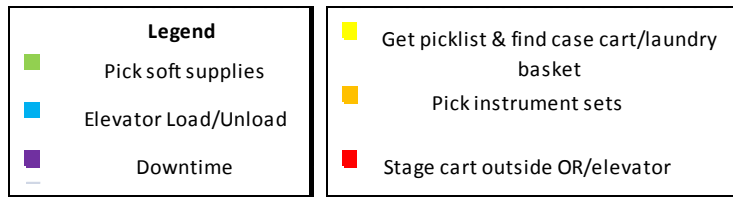
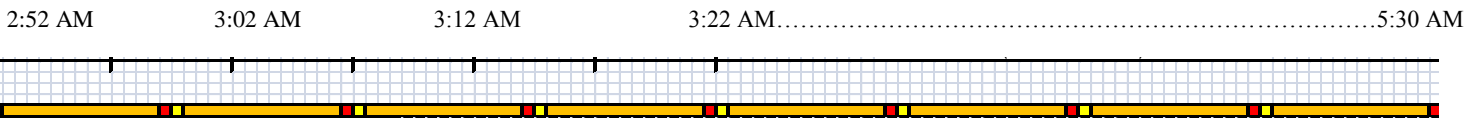

Part 2: Loading/unloading: Send 4 case carts at a time up the elevator for first 27 cases immediately. Use pull system for subsequent cases.

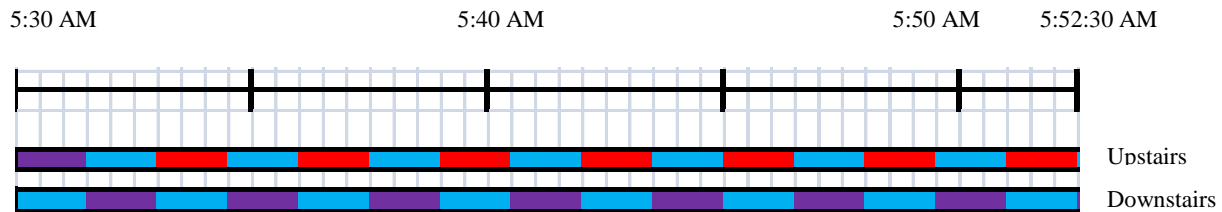

Figure 9. Future state picking and staging to complete case carts for all cases of the day by 6AM

Part 2 of Figure 9 requires 1 instrument processor downstairs in the CSPD to only load the 4 case carts onto the elevator and send the elevator upstairs to the OR Cores (light blue). In the CSPD, loading the 4 case carts will take approximately 30 seconds. Sending the elevator upstairs will take 1 minute. The 4 PT's upstairs will unload the case carts out of the elevator and immediately send the elevator down stairs (light blue). The instrument processor downstairs will have to wait every time for the elevator to come back downstairs. During this downtime, the instrument processor can check the case carts against the Pick Sheets to ensure quality. This process should take 1 minute, 30 seconds. After the 4 PTs send the elevator downstairs, the 4 PTs have the total time equivalent for the elevator to come back upstairs to stage the case carts outside the ORs with their corresponding laundry baskets of soft supplies (red). The total time for PTs to unload the elevator, stage the case cart, and return to the elevator requires 7.5 minutes. This staging includes the time required for the PT to add the laundry basket to the case cart and for the PT to return to the elevator. To stage the case carts for the first 27 cases of the day by 6:00 A.M., case cart staging can begin at 5:30 A.M, immediately after the picking process.

## Emergent Case Model

There are two types of emergent cases that most frequently occur: a true emergency situation that needs a picked case cart in less than 5 minutes and an urgent case that needs a case cart ready in 10 minutes. The team created a model for each of these types.

### True Emergency

In the case of a true emergency a pre- prepared trauma case cart is used equipped with all the soft supplies and instruments needed for any type of surgery coming into the OR. This cart will remain upstairs for quick and easy accessibility. Figure 10 models the time required to stage the case cart in the OR.

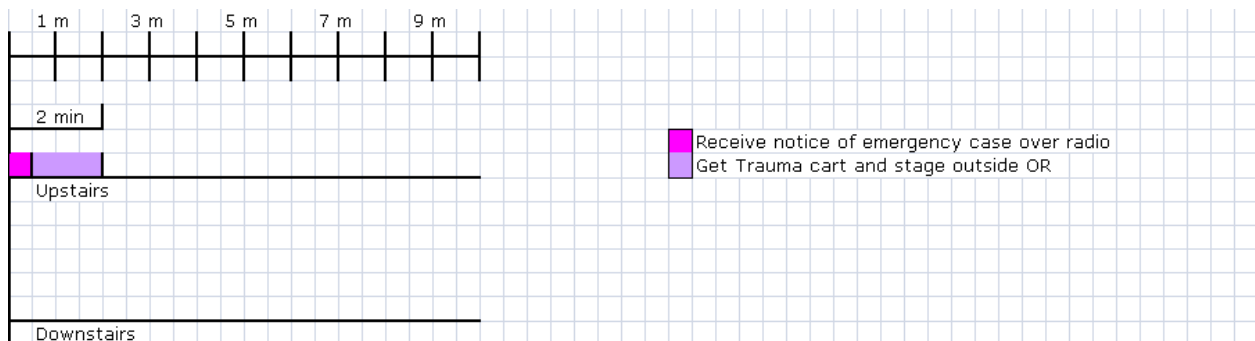

Figure 10. Future state model to pick and stage true emergency cases

The team estimated that it would take 30 seconds to receive the message over the radio that a trauma cart is needed based on PT interview responses. Locating the cart would take approximately 30 seconds and staging it would take an addition minute. Therefore, the entire process should take 2 minutes to complete which is less than the required 5 minutes. The main assumption in this model is that there is a PT available to receive the emergency case message. The staffing for this model requires 1 PT in the OR Cores.

### Urgent Cases

Ideally when time is allowed, specific case carts will be picked according to a Pick Sheet for the emergent surgery. However, realistically there is not always time to do so. In the current state, the front desk clerk generates a Pick Sheet electronically and contacts a PT on the radio to pick the urgent case. Once the Pick Sheet is printed, all the available PTs help pick the soft supplies and instruments according to the Pick Sheet. The PTs stage the equipment on a bipod outside the OR. In the future state, the front desk clerk will need to contact both a PT in the OR Cores and an instrument processor in the CSPD. Figure 11 models how the picking and staging process will change in the future state.

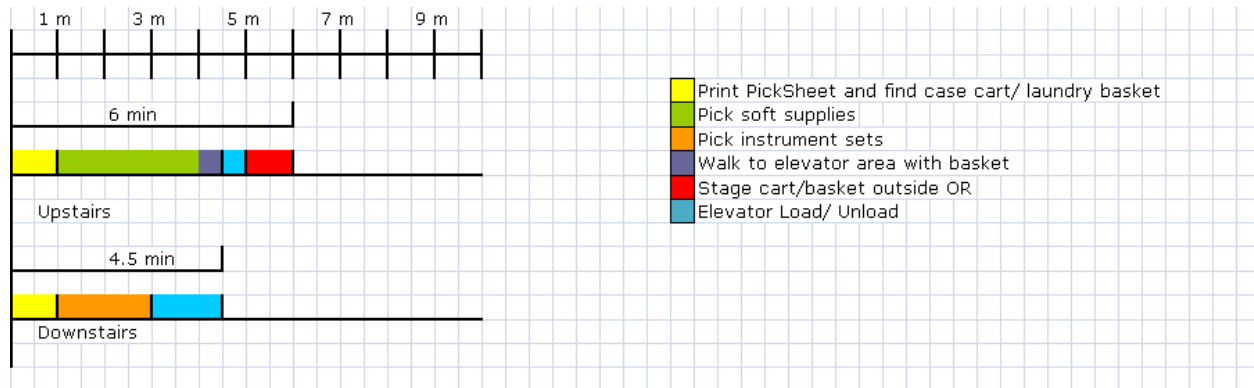

Figure 11. Future state model to pick urgent cases

If one follows the above model, the entire picking and staging process of an urgent case cart should take 6 minutes which is less than the required 10 minutes. Picking for urgent surgical cases should take roughly 1/3 the total time it normally takes in Figure 7. This estimate is based on interviews with multiple PTs that stated more helping hands tends to reduce the overall processing time by 1/3. The main assumption in this model is that there are 3-4 PTs upstairs and 1-2 instrument processors downstairs that can help pick the case.

## RECOMMENDATIONS

The team has provided recommendations for the OR Cores and CSPD to efficiently pick the soft supplies and hard instruments in parallel based on the surgical case demand throughout a typical weekday. These quantitative recommendations include how the picking process should be scheduled according to the first cases of the day, subsequent cases of the day and during emergency case scenarios. The qualitative recommendations include solutions for quality improvement and organization.

### First 27 Cases of the Day by 6:00 A.M.

The instrument processors in the CSPD and the PTs in the OR Cores should commence the picking of the first 27 cases of the day at exactly 5:22 A.M. or more reasonably at 5:00 A.M. (with added buffer time) to ensure all case carts are staged outside their respective ORs by the goal time of 6:00 A.M. (1 hour in advance requirement for the 7:30 A.M. surgical case start time). This goal time requires a staff 2 groups of 5 PTs in the OR Cores and 2 groups of 4 instrument processors in the CSPD to reduce the most waste by keeping the elevator loaded as much as possible and moving frequently. The fifth PT in both groups will be solely responsible for just unloading the elevator with all 4 case carts and staging every single one. Under this staffing, the process will take approximately 38 minutes for all case carts to be picked and staged, assuming soft supplies and instruments are picked in parallel. If staffing 18 people is undesirable, the hospital could staff 1 group of 5 PTs in the OR Cores and 1 group of 4 instrument processors in the CSPD. The entire process would finish in twice the amount of time or 1 hour and 16 minutes. In order to ensure all case carts are staged outside their respective ORs by 6:00 A.M., the process should commence exactly at 4:44 A.M. or more reasonably at 4:30 A.M. to allow extra buffer time.

## **Second and Third Cases of the Day**

The instrument processors and PTs should pick the second case carts of the day at 8:00 A.M. to ensure case carts are staged outside the ORs by 8:30 A.M. which is usually the start time of the second surgical case. The hospital needs to staff one group of 4 PTs in the OR Cores and one group of 4 instrument processors in the CSPD. Since demand during this time period has dramatically reduced, a fifth PT becomes unnecessary and the number of groups upstairs and downstairs will reduce to one group each. Under this staffing model, it will take 21.5 minutes to pick for 8 surgical cases.

## **81 Cases of the Day by 6:30 A.M.**

To ensure 81 case carts are staged at the ORs by 6:00 A.M. and assuming all picking begins on the midnight shift, the instrument processors should begin picking at 2:52 A.M. The PTs should begin picking at 2:30 A.M. Both instrument and soft supply picking will end at 5:30 A.M when loading the elevator to maximum capacity can begin. One instrument processor whose sole responsibility is elevator loading will send the first 4 case carts up the elevator. While the instrument processor waits for the elevator to come back down, he or she should check the next set of case carts against the Pick Sheets to ensure quality control. When the elevator reaches upstairs, the PTs will unload the elevator and immediately send it back down. The PTs will match the soft supplies with the corresponding case carts and stage the case carts outside the ORs. This elevator loading/unloading and staging process will repeat only for the first 27 cases of the day. The hospital should stage all case carts for the first 27 cases of the day at once. However for the later cases, the hospital may find it optimal to send case carts up the elevator closer to those case start times to avoid congestion. Another reason to support the picking process at 2:30 or 2:52 A.M. is the fact that the hospital is adding 3 sonic washers, 3 advanced H<sub>2</sub>O<sub>2</sub> sterilizers and 4 decontamination centers (see Appendix C). These additions should speed up the current instrument sterilization process which will increase the likelihood that the instruments will be sterilized in time for picking.

## **Emergency Cases**

A pre-prepared trauma cart should be assembled for every different type of service and stored in the appropriate OR Core. Locating and staging the trauma cart should take 2 minutes to complete.

## **Urgent Cases**

The hospital should implement an effective radio communication system so that the front desk clerk can notify both the PTs and instrument processors simultaneously when there is an urgent case. Since surgical cases require on average 6.6 instrument sets (range: 1-15), only 1-2 instrument processors are necessary to pick these items under 5 minutes (Table 1). However, surgical cases require on average 44 soft supplies (range: 14-80) which can be picked in under 10 minutes provided 3-4 PTs are available to help pick the entire case cart (Table 1).



## Summary of Quantitative Recommendations

Table 2 summarizes the three models in a descriptive matrix that shows the time the picking and staging process needs to begin, the number of man-hours or full time equivalents required to complete the process, the number of staffing needed and the percent utilization of the staff over the specified timeframe. In Table 2, the matrix shows the results for 9 staff versus the optimal 18 previously mentioned in the first case of the day model. Staffing 9 people versus 18 was taken into consideration since it may be difficult for the hospital to hire 18 staff for an hour duration.

Table 2. Descriptive statistics for picking and staging processing times.

	Demand	FTEs	Staff Required	Percent Utilization
1st Cases (4:44-6am)	27/hour	4.3	9	100% upstairs 59% downstairs
2nd & 3rd Cases (8:30am-5:30pm)	8/hour	4.5	8	35.83% upstairs 26.67% downstairs
Non-scheduled Cases (5:30pm-5am)	0-2/hour	--	2	18.33 - 36.67% upstairs 13.33% - 26.67 downstairs

The next set of recommendations is applicable for case cart quality check. These qualitative recommendations include a color coded system, double-checking and a scanner or barcode method.

### Color Coded Stickers

The hospital should more frequently utilize their existent color coding labeling system which organizes all the Genesis cases and wrapped instrument sets by service or surgery type. This would prevent the staging of the wrong instrument set in ORs. Currently, each color represents a different type of service (e.g. neurology, urology, gynecology). The colored sticker would be placed on each Genesis case or wrapped instrument set for a particular type of a service and on the Pick Sheet. Before loading the elevator, the instrument processor will review the stickers on the instrument sets as a quality check before sending it up the elevator. This method is sustainable for short-term usage because it is inexpensive, easy to use, and requires a short time to implement.

### Manual double checking

For the models following the 24-hour surgical case demand, the CSS manager may designate one instrument processor to check the instrument sets on each case cart before loading it into the elevator. The instrument processor that finishes picking the last case cart of each batch would

check the instrument sets on all 4 carts against the Pick Sheet. If the instrument sets are correct, the instrument processor would load the elevator with that case cart upstairs. If the instrument sets do not match the Pick Sheet, the instrument processor would quickly re-pick the case cart before loading the elevator completely and sending the case carts upstairs. This recommendation would be inexpensive and require consistent effort and commitment from the instrument processors. However, since the last instrument processor needs extra time to perform the check, the picking process in the CSPD will likely slow down and fall off schedule. To mitigate this, the hospital may opt to hire an extra personnel whose responsibility is to perform the manual check, but to staff this extra person during one shift may not be feasible. For the last model which schedules 81 case carts by 6:00 A.M., the instrument processor who is only loading the elevator can perform a manual quality check during downtime hours seen in Figure 9.

## Barcode system

The hospital should continue to implement its current barcode system as a more sophisticated means of maintaining quality and accuracy. All Pick Sheets and instrument sets would be marked with a unique barcode as shown in Figure 12. The instrument processor would scan the barcode of the Pick Sheet then scan the barcode of all Genesis cases and wrapped instrument sets for that Pick Sheet's surgery or service. If the wrong instrument set was scanned, the computer would generate an error message. This barcode method is sustainable for long-term usage because scanning would yield far more accurate results at a much faster rate due to automation versus manual checking. However, it would be relatively more expensive and require longer time to deploy compared to other alternatives. One suggestion would be to utilize the color-coded system or the manual double checking for short-term usage until a full-scale barcode system can be implemented long-term.



Figure 12. Barcode on a Genesis Case for a neurology surgical case. *Photograph taken by IOE 481 Team 6, October 2010.*

## Summary of Qualitative Recommendations

Table 3 summarizes the advantages and disadvantages for each of the recommended solutions to improve the quality and accuracy of the case carts during the picking and staging process.

Table 3. Pros and Cons for Each Recommendation for Quality Checking

Qualitative Check	Pros	Cons
Color Coded Stickers	Inexpensive Easy-to-use Short implementation time	Requires training Subject to human error
Manual Double Checking	Inexpensive Minimal Effort Short implementation time	Affects CSPD cycle time Subject to human error Difficult to staff extra person
Scanner/Barcode	Higher accuracy rate Automated More efficient	Expensive Long Implementation time

## EXPECTED IMPACT

If the team’s recommendations are implemented, the CSS manager and instrument room interim manager can expect an optimally efficient instrument and soft supply picking and staging procedure running in parallel between the CSPD and OR Cores. Provided the number of PTs and instrument processors are available during each shift, the CSS manager and instrument room interim manager can determine the length of time required to process each batch of 4 case carts based on the number of man-hours (FTEs) worth of work. By decreasing the staff for the second and third cases of the day, the hospital can still meet the reduced demand, and PTs and instrument processors will be able to complete the rest of their workload unrelated to picking and staging. The hospital can also adjust their staffing and scheduling to deliver case carts for all 81 cases of the day by 6:30 A.M. using the parallel model. This process will allow the hospital to stage case carts in the CSPD by the elevator. The hospital should load all the case carts for the first 27 cases of the day. However, case carts can be loaded up the elevator on a “just-in time” basis for later cases since staging all case carts at once will most likely congest the OR Cores.

## ACKNOWLEDGMENTS

The team would like to credit the following people for their contributions and project assistance.

Linda Lawrence, Instrument Room Interim Manager

- Provided ongoing details of the problem statement, project requirements, expectations, current workflow logistics and contact information
- Provided tour of the OR Cores and instrument processing rooms

Karen Bett, Central Sterile Supply Manager

- Provided ongoing details of the problem statement, project requirements, expectations, current workflow logistics and contact information
- Provided tour of the CSPD

Heather Mlynczyk, Patient Care Tech Associate

- Coordinated interviews with PTs
- Assisted in time study preparation

Sami Hensler, Patient Care Tech Associate

- Assisted in time study preparation

Matthew Claysen, Project Coordinator

- Served as project's mentor and liaison to the main clients
- Provided UMHS historical data, blueprints of the CSPD and OR Cores, case cart prototype
- Provided team useful feedback on the project's progress and help maintained the team's professional skills

Mary Duck, Project Coordinator

- Helped the team narrow the project's scope and focus
- Provided useful feedback on the project's progress

# **APPENDIX A: BLUEPRINTS OF UMHS OPERATION ROOM CORES**





# Overview of UH OR Core C Layout

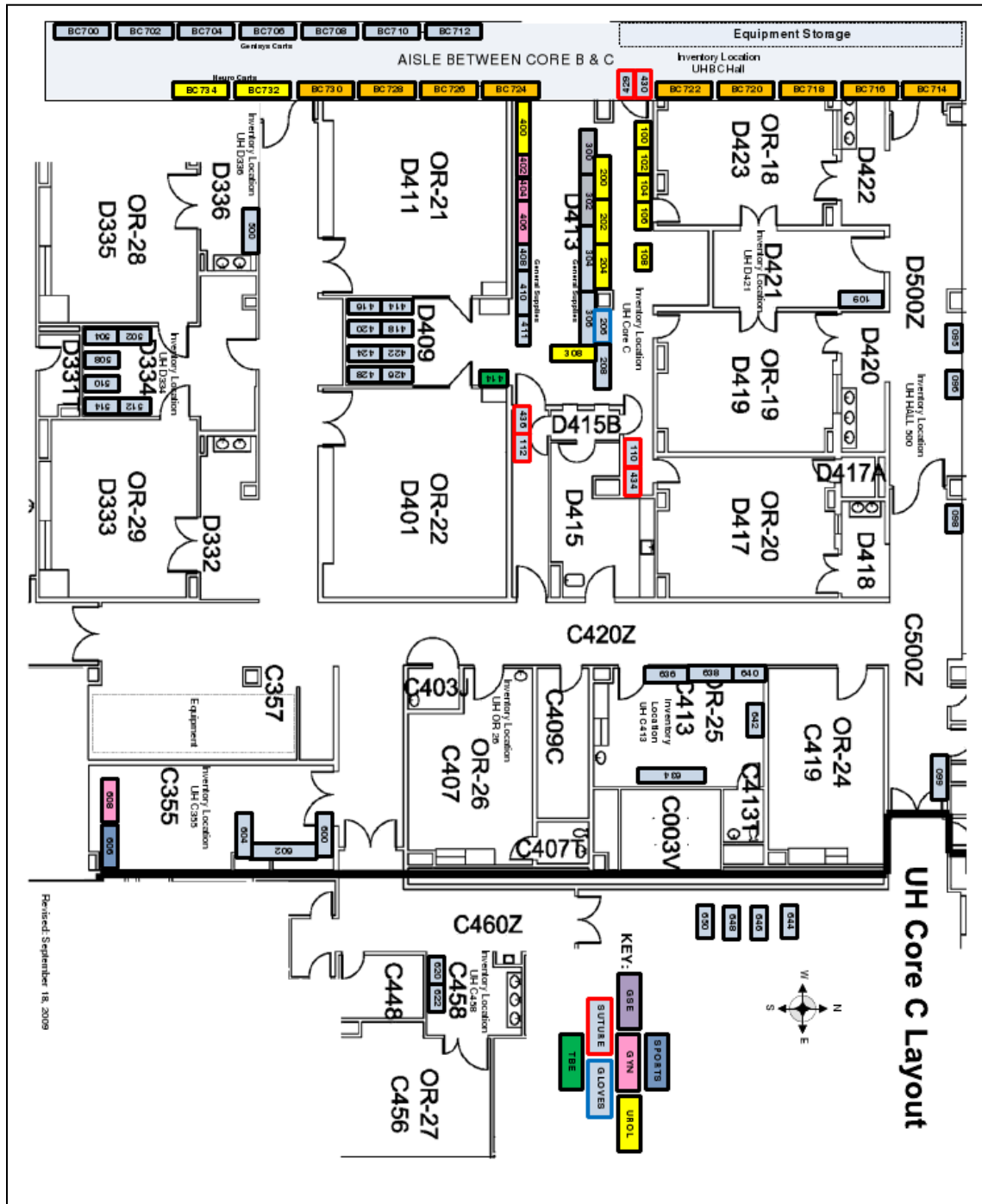

Provided by Team Project Coordinator, Matthew Claysen, October 2010



# Overview of CSPD Layout

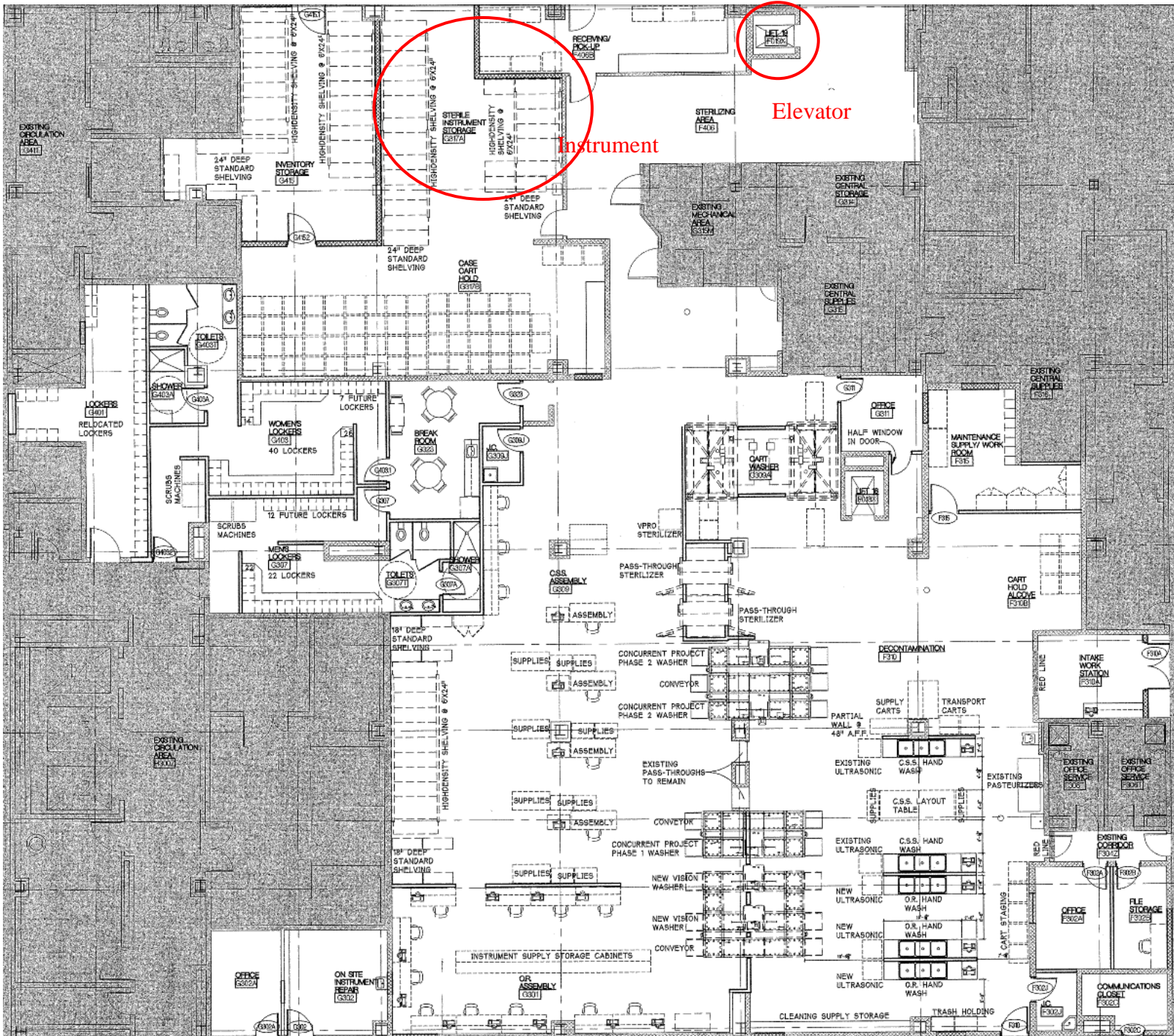

Provided by Team Project Coordinator, Matthew Claysen, October 2010

# APPENDIX B: VALUE STREAM MAPS OF CURRENT STATE

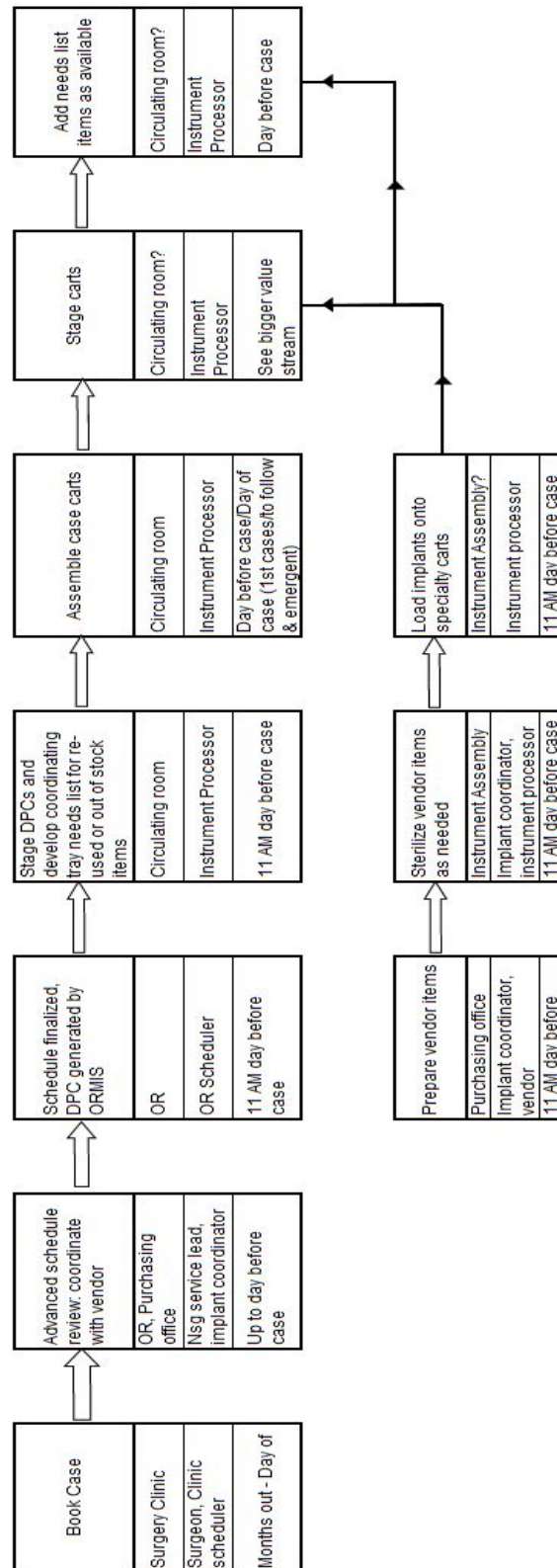

## APPENDIX C: HOSPITAL EQUIPMENT

Table 1: Equipment Currently Available in Basement Area

Cleaning and Sterilization Equipment	Number Available	Set Capacity	Avg Time to Process (min)
Sonic Washers	2	2	30
Decontaminators	5	12	25
Floor Loading Steam Sterilizers	4	2	60-90
Carton Carriage Sterilizers	2	2	60-90
Gas Sterilization Units	3	2	60-1440
Decontamination Stations (3 sink each)	1	---	---

Table 2: Equipment Currently Available on Same Floor as OR Cores

Cleaning and Sterilization Equipment	Number Available	Set Capacity	Avg Time to process (min)
Sonic Washers	1	2	10
Decontaminators	3	12	25
H2O2 Sterilization	4	2	30-60

Table 3: Equipment Added to Basement Area in the Future

Cleaning and Sterilization Equipment	Number Available	Set Capacity	Avg Time to process (min)
Sonic Washers	5	2	30
Decontaminators	5	12	25
H2O2 Sterilization	1	2	30-60
Advanced H2O2 Sterilization	3	2	30-60
Decontamination Stations	5	---	TBD
Cart Washers	2	—	---

*Provided by Team Project Clients, Linda Lawrence and Karen Bett, October 2010.*